

## Design Data

Rated Flow (gpm)	300	Proj. Effective Area (sq. ft.)	940
Flash Volume (gal.)	262	Floc Volume (gal.)	1110
Hopper Volume (gal.)	1467	Shipping Weight (lbs.)	20100
Plate Spacing (inch)	2	Operating Weight (lbs.)	91800

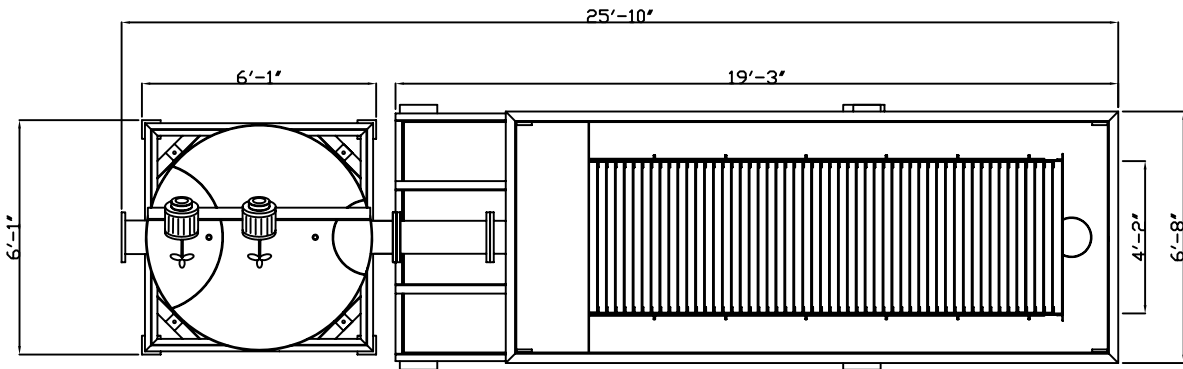

**PLAN VIEW**

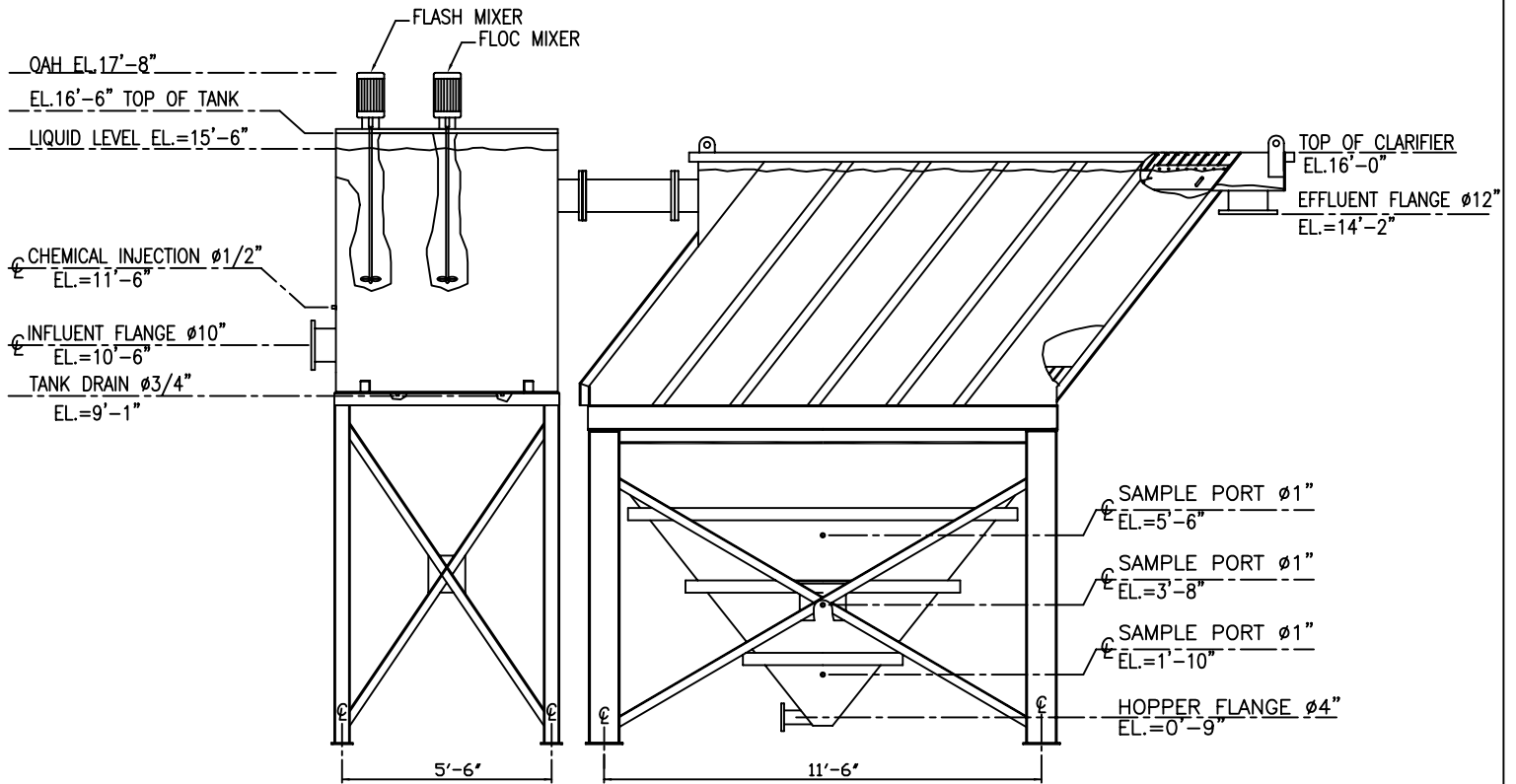

**SIDE ELEVATION**



UniPure

**-CONFIDENTIAL-**

NOT TO BE DISCLOSED, USED OR DUPLICATED  
EXCEPT AS AUTHORIZED IN WRITING BY UNIPURE

TITLE:

UniPure 300-940-G2 Clarifier  
Design Data

DWG No.

C300DD